

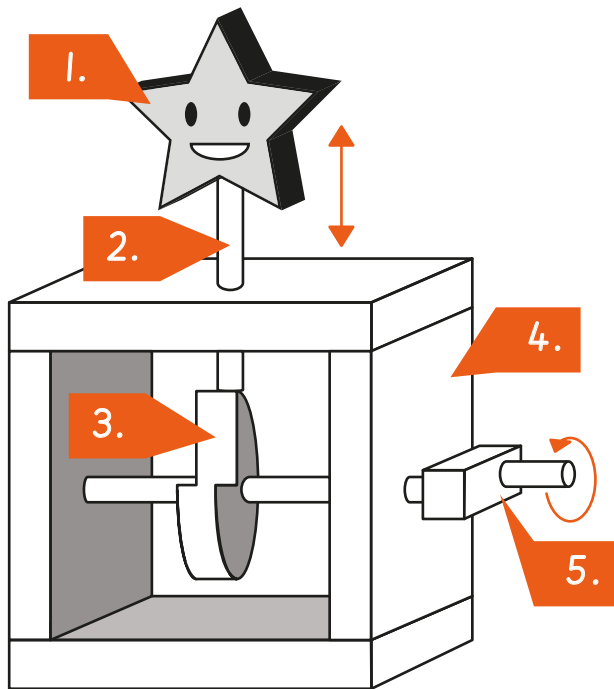

Automata toy components:

1. Character.
2. Follower.
3. Cam.
4. Frame.
5. Axle attached to handle.



Automata toys use a mechanical system of cams, axles and followers to create movement in a character or object.

Exploded diagrams

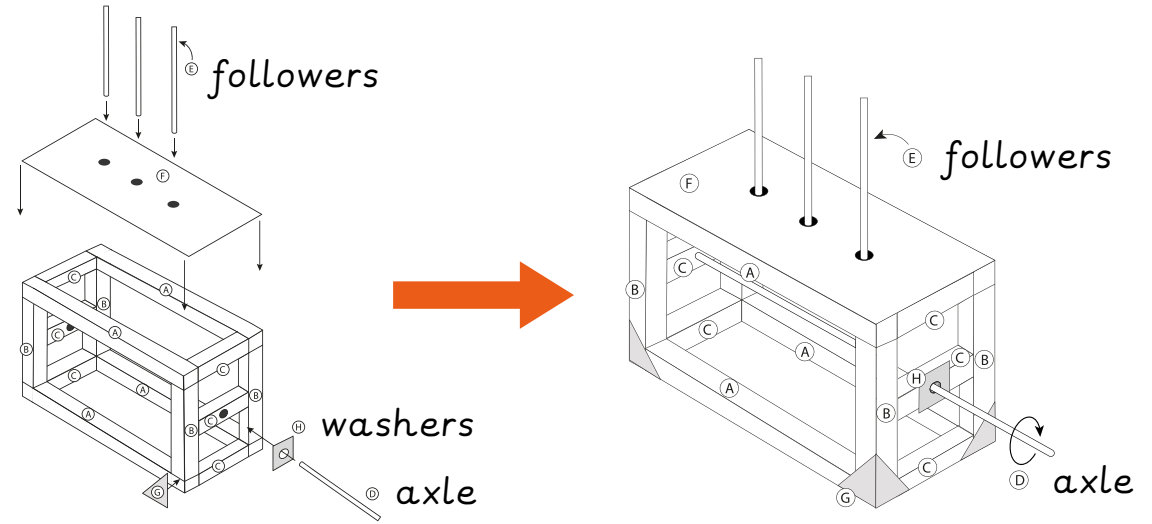

Exploded diagrams communicate how the parts of a product fit together. They help when making the product.

Cross-sectional diagrams

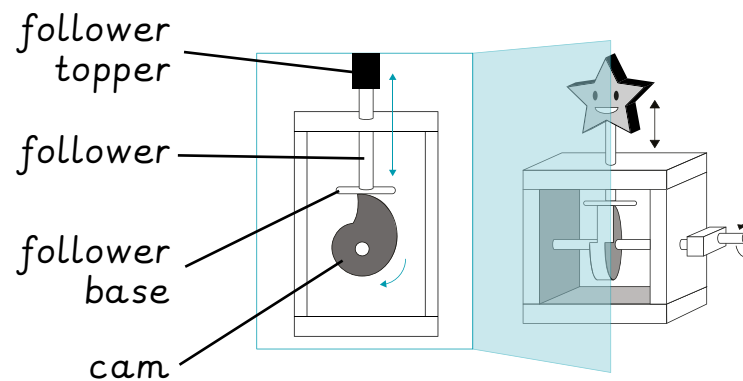

Cross-sectional diagrams help designers to communicate how a product works by showing the inside. Imagine a cut down the middle.



Making adjustments and improvements

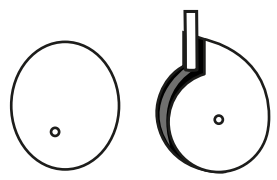

Increase the thickness of the **cams** by using corrugated card or sticking the same shape **cams** together.

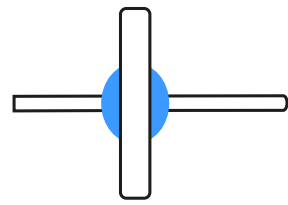

Secure the **cam** to the **axle** with sticky tack or modelling dough so the **cam rotates** with the **axle**.

Make sure the frame is straight.

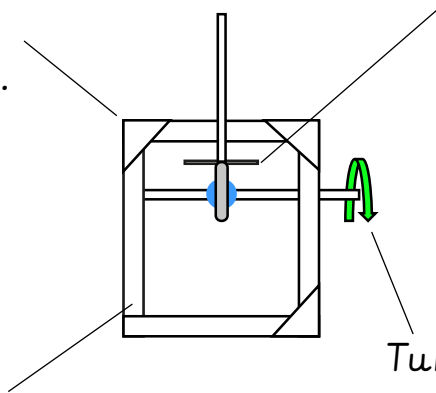

Make sure the base of the follower is touching the cam.

Add material to straighten the frame.

Turn the axle smoothly. Add a handle to make this easier.

Follower movement

The shape of the **cam** changes the movement of the **follower**. Cams can change **rotational** movement to **linear** movement.

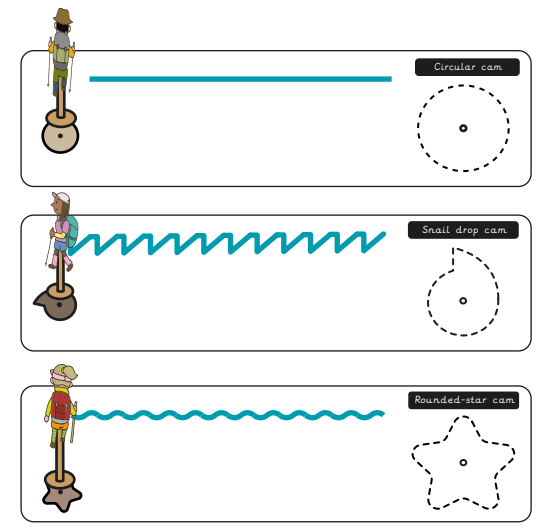

Cam shapes

eccentric cam	snail drop cam	heart cam	circular cam
pear cam	oval cam	star cam	square cam